

GEAR UNIT CAD CONFIGURATION

TYPE	MI
SIZE	130
DOUBLE EXTENDED WORM SHAFT	NO
PAM	PAM112B14
HOLLOW OUTPUT SHAFT	D.48
FIXING VERSION	OUTPUT FLANGE
MOUNTING POSITION	F - POSITION DX
	B5

ACCESSORIES

OPTIONAL

MOUNTED ELECTRIC MOTOR	NO
TORQUE LIMITER	NO
TORQUE ARM	NO
SOLID OUTPUT SHAFT	NO

ATEX	NO
LUBRICANT	SUPPLIED WITHOUT LUBRICANT

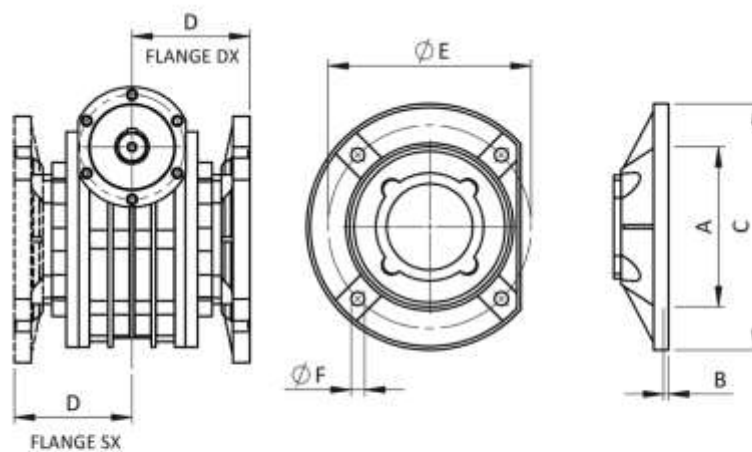
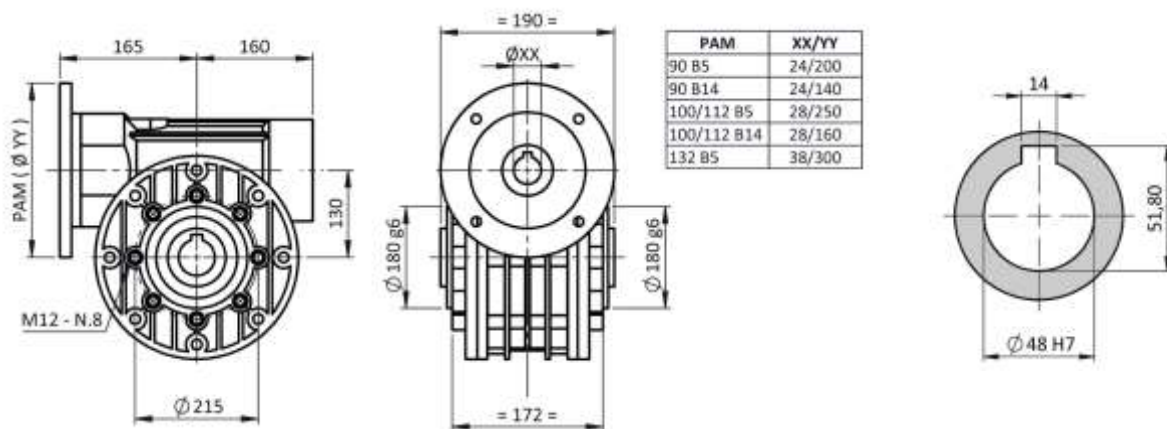

TYPE	A	B	C	D	E	F
F	∅ 230 H7	5	∅ 300	150	265	15
FBR	∅ 230 H7	5	∅ 300	137,5	265	15

AVAILABLE ACCESSORIES

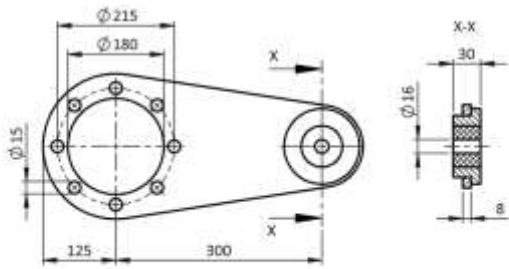

TORQUE ARM

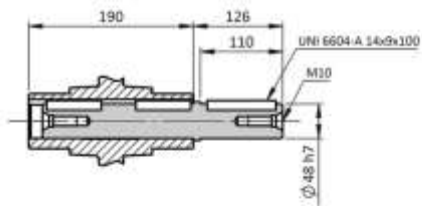

SINGLE EXTENDED OUTPUT SHAFT

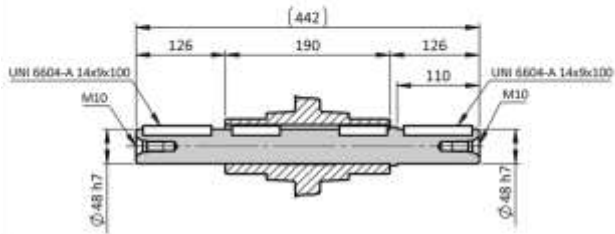

DOUBLE EXTENDED OUTPUT SHAFT

